

Ozone is Not Just for Residential Potable Water Treatment

By Marc De Brum

It has been over 170 years since the discovery of the ozone (O_3) molecule. Since that time, scientists and engineers have been testing and evaluating ways to use ozone in many different processes, from water and air treatment to surface and food sanitation. The evolution was somewhat slow in the early days, taking nearly 50 years before Europeans found, in 1886, that ozone could be used for water disinfection. From that point, it continued to pique the interest of those in pursuit of developing safe water treatment practices. Another well-known application, however, has brought ozone to the forefront: the treatment of swimming pool and spa water. The US saw its first use of ozone in a commercial pool in 1937, and has continued to use ozone for its oxidative qualities since. In more recent years, ozone has been the oxidizer of choice, and mandated for use of all Olympic training and competition swimming pools, for its disinfection and oxidation capabilities. Over the last century, ozone generation equipment has evolved and is now available on a small scale for residential use. Water treatment professionals may already know of ozone's potential, and may be using it as another tool in their bag for these small-scale residential water treatment applications. With better knowledge and understanding of ozone and the residential pool and spa application, they may also be able to use this same tool to obtain more business from their current customer database.

Oxidation strength of ozone

Oxidizers react with organic and inorganic compounds by donating or receiving electrons and can improve water quality by sanitizing and precipitating (causing suspended contaminants to drop out of the water as solids). The most recognized commercially available oxidizers include chlorine

Figure 1. Relative oxidizing strength of oxidizers (chlorine set = 1.00V)

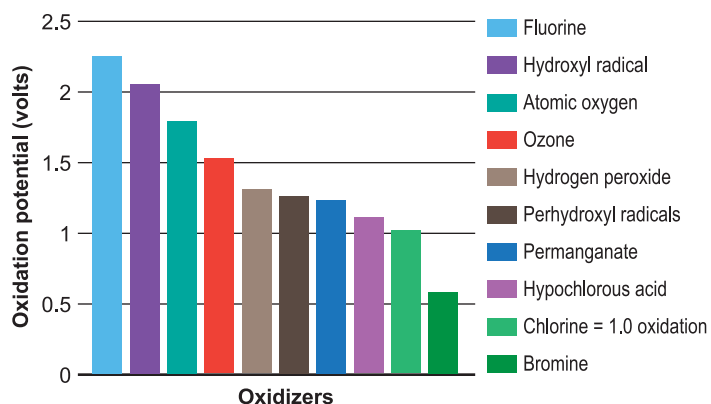

(gas and liquid), hydrogen peroxide and bromine; however, ozone still remains the most powerful oxidizer commercially or, in this case, residentially.

Benefits of ozone

Because of ozone's high oxidation potential, it can change the molecular structure of organic and inorganic compounds, allowing them to be precipitated from pool water. Once these compounds are precipitated, ozone also helps to flocculate (or bind) the precipitated solids together, allowing them to be easily removed from the water via the pool filtration system. These compounds can include lotions, body oils, sweat and saliva among others. Ozone is also most effective in killing bacteria, cysts and viruses up to 3,125 times faster than chlorine, which is one reason it is used for the disinfection and purification of municipal and residential water treatment supplies worldwide. Ozone can also be very effective in killing algae spores that travel through the ozone contact system. Due to its short half-life, however, it is recommended that a small residual of chlorine (often 0.2 to 0.5 ppm) or an algacide (such as a phosphate remover) be used in residential pool or spa waters to prevent algae blooms, in addition to scheduled brushing of the pool walls and standard pool maintenance. A key benefit to the use of ozone in swimming pools and spas is not only its ability to oxidize, but also to destroy bacteria and viruses completely—unlike chlorine—with the only byproduct being oxygen. Chlorine often does not have enough contact time to completely oxidize these contaminants, causing chlorine oxidation byproducts called trihalomethanes (THMs). THMs, some of which are carcinogens, are often measured in pool water as combined chlorine, and are the cause of the chlorine smell, faded swimwear, burning eyes and green hair. Ozone, on the other hand, will not only destroy the contaminants completely, but can also oxidize the byproducts of chlorine disinfection, all from a product that can be easily and safely generated onsite.

Target residential pool conditions

Although requirements can change from pool to pool, most standard pool water treatment parameters are going to remain the same.

pH

Ozone is a pH-neutral oxidizer, which means when ozone is used, pH will not fluctuate or 'bounce' like it does when chlorine is used; therefore, the need to adjust pH is less frequent. For best results, it is recommended to keep pH between 7.0 and 7.6. This range is required for two reasons: first, as pH drifts above or below these levels, ozone becomes less effective and

second, if chlorine is used as the secondary residual sanitizer, a higher percentage will be hypochlorous acid, which is the key component for chlorine sanitation. As pH increases, there is a greater percentage of hypochlorite ion, which is a far weaker oxidizer than its hypochlorous acid counterpart.

Total alkalinity (TA)

This is a measurement of water's resistance to change pH. To achieve a required pH level without a lot of pH bounce, it is best to keep TA at 80 to 150 ppm. If too low, pH can drop very quickly, causing cosmetic damage to the pool walls; if TA is too high, pH can increase, causing the oxidizer (ozone or chlorine) to be ineffective. Cloudy water and scaling may occur.

Calcium hardness

It is important to keep hardness at 200 to 270 ppm for plastered pools. If the hardness is too low, the water will leach calcium from the plaster, causing the walls to become pitted, damaging the surface. If the hardness is too high, scaling may occur.

Free-chlorine

This is a measurement of free available chlorine to perform oxidation of pool water. Often, when ozone is used as the primary sanitizer, free available chlorine can range from 0.1 to 0.5 ppm in residential pools and spas. As less ozone is used for oxidation, chlorine begins to take on the role of the primary sanitizer. Because chlorine is a weaker sanitizer, a greater residual of chlorine should be used to take on the oxidation required, typically ranging from 0.8 to 1.5 ppm. With high bather loads, however, and low quantities of ozone ppm (< 0.15) greater levels of chlorine may be required to achieve proper sanitation and oxidation results.

Oxidation-reduction potential (ORP)

This is the standard for pool sanitation measurement. Displayed in an electrical millivolt (mV) reading, as ORP levels increase, the better the oxidation and sanitation of the pool water. Conversely, as ORP drops in millivolts, the poorer the pool water will be, with increased contaminant load, which will require oxidation. When ozone is used as a primary sanitizer and chlorine is used as a residual sanitizer, it is not uncommon for ORP levels to reach that of bottled water standard (650 mV) or above.

Temperature

Most residential pool owners will set pool heaters between 75-82°F (23.88-27.77°C). As temperature increases, ozone's (and chlorine's) effectiveness decreases. It is always helpful to understand the customer's preference prior to sizing the appropriate ozone equipment, so that these parameters can be accounted for.

Plumbing design considerations

There are two standard plumbing configurations that are used to introduce ozone into pool

or spa water: the independent loop and the side-stream loop. Both configurations have pros and cons; typically the determining factor is whether the ozone system is being installed for a newly constructed pool or if an existing pool is being retrofitted.

Independent loop

The independent loop configuration is primarily used with new construction projects because water that is supplied to the ozone system requires a separate suction plumbing line from the pool and separate plumbing return line back to the pool (see Figure 3). Utilizing an independent pump and plumbing allows the system to be operated for sanitation and oxidation purposes at any time during the day, as opposed to only when the main circulation system is in operation. The independent loop, however, may be used in some retrofit projects when plumbing lines are readily available. Another benefit is the simplicity of the system hydraulics. The only components that are plumbed into the water line are the ozone injection manifold, which draws ozone gas into the water line, and an ozone contact tank. This allows the booster pump to drive the injector and return the water back to the pool without valves, a heater, or other components causing backpressure and water flow issues that can be counteractive to the operation of the ozone injection system.

Side-stream loop

The side-stream loop is traditionally for retrofit projects that do not have additional plumbing lines from and to the pool, as adding these lines after the fact would not be cost effective. This loop is designed in a way that a portion of the water from the full-flow circulation line is diverted to the side-stream loop. This diversion is best created downstream of the main circulation filter prior to the systems heater, allowing the coolest filtered water possible to be sent to the ozone injection point. From this point, water pressure and/or flow may be boosted with the aid of a booster pump, which is then directed towards the ozone injection manifold. There, ozone is drawn into the water line, prior to the water containing ozone entering the contact tank. Once water has been contacted with ozone in the tank, it is then returned to the full-flow water line downstream of the system heater (see Figure 4). (NOTE: The return line or ozone injection point should always be far upstream of the residual sanitizer and pH adjustment chemical injection point.) This is the best location for the side-stream configuration because if the ozone injection point were upstream of the heater, ozone could oxidize heater

Figure 2. Recommended residential pool conditions with the use of ozone

Parameter	Range
pH	7.0 - 7.6
Total alkalinity	80 - 150 ppm
Calcium hardness	200 - 270 ppm
Free chlorine	0.1 - 1.0 ppm
ORP	> 700 mV
Temperature	75 - 82°F (24 - 28°C)

Figure 3. Independent loop plumbing configuration

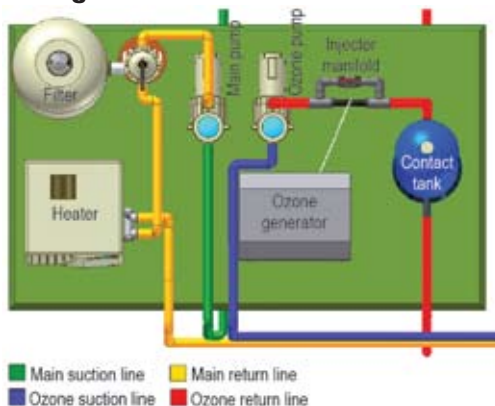
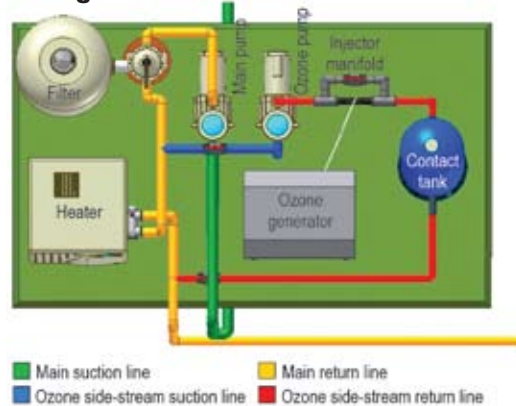

Figure 4. Side-stream plumbing configuration



components over time, causing the heater to fail. In addition, hot water would destroy some of the ozone as it travels through the heater, rendering the ozone nearly ineffective. Furthermore, if the ozone injection point were downstream of the heater, hot water would also destroy some of the ozone, causing it to be less effective. If, however, there is not another suitable place to install the ozone injection point and contact vessel, then this position is acceptable.

The side-stream configuration can be used for nearly all retrofit applications. In addition, this method can be designed for some applications without the use of an additional booster pump, although it is shown with one in Figure 4. The booster pump drives the injector, which operates via a differential of pressure. Depending upon other components and elevation of the equipment pad (above or below grade), there may be added back pressure on the ozone injector, keeping it from creating the vacuum required to draw ozone gas into the water line. Any time there is a potential for additional backpressure, this booster pump will typically be required; otherwise it may not be necessary. Most equipment pads that are at or above grade do not have the added backpressure due to the static head of the pool. The pump may not be required, as the pool heater will create a greater differential than the ozone side-stream loop, allowing ozonated water to be fed back into the lower pressure line of the full flow.

Ozone system sizing

For most, sizing an ozone system can be a daunting task; however, with the correct tools and information, it is a fairly simple process. Prior to sizing an ozone system, collect information regarding the feature, creating a system profile that will be helpful to determine the proper system. The system profile should include several factors to achieve a successful, properly sized ozone treatment system. A great starting point is to ask customers what they feel their goal is for implementation of an ozone system. The typical response in the case of a residential pool or spa is to reduce chlorine! The question becomes, "How much chlorine do you want to reduce?" Most often, the reason for the reduction (or in some cases elimination of chlorine) is that clients do not want to deal with chlorine odor in the water or on their skin, and other issues that are caused by chlorine oxidation. Again, all of these problems are due to the byproducts of chlorine oxidation. Often, whether using low or ultra-low chlorine levels, a properly sized ozone system can achieve the treatment goals required by still using a small residual of chlorine, while eliminating its negative effects. With some extra pool maintenance, even a chlorine-free approach can be achieved with the use of ozone.

To determine exactly how much total water needs to be treated, an understanding of the water feature's physical size and water volume should be noted prior to choosing a system. A few finer points that should be considered regarding the system hydraulics include plumbing size, flowrates, whether the equipment pad is above or below grade and indoor or outdoor, how the residual sanitizer is being administered and whether there is a pool water heater. This information noted at the beginning of the project will be of use once it is time to size peripheral equipment and install the ozone system. Knowing the oxidation load of a pool or spa is an integral component to the proper sizing of an ozone system, since with more load, the ozone will be consumed quicker. Because ozone has a short half-life, it must be replenished to the water on-demand to be able to meet the oxidation load or demand. Oxidation load can come from various places around the pool, including dirt or debris dropped into the pool from the wind, animals in the pool and of course, swimmers, which should be noted as high, moderate or low bather-load levels. Considering these factors, calculations

can be derived to determine the proper ozone output required to provide adequate oxidation and sanitation.

Determining the best ozone dosage rate

Ozone dosage rate will vary depending upon conditions and bather load. This rate will also be calculated based upon the full-flow gpm of the feature's main circulation pump. A standard equation to determine full flow is: volume/360 minutes (six-hour turnover) = turnover gpm. Standard dosage rates will vary from 0.1 to 0.5 ppm ozone. Conditions that will affect this dosage are water temperature, indoor or outdoor pool or spa, covered or uncovered, bather load, filtration type and chemical-use reduction. Heavier dosage rates (0.5 ppm) are recommended if one or more of the following conditions exist: extremely high bather load, outdoor pool or spa subject to heavy debris, poor filtration (filter maybe old) or chemical-use reduction.

Unfortunately, many pool and spa owners who have tried ozone have not achieved the benefits of its use, often due to being sold on the buzzword instead of the benefits. Ozone is often oversold as a cure-all but undersized for the application. To provide true benefit, systems must be sized correctly for each individual feature. By not relying on the cookie-cutter, one-size-fits-all approach, systems can be sized specifically for the customer, keeping costs down, while providing sufficient ozone production for the feature to meet customers' goals.

Example

System profile

Treatment goal: Ultra-low chlorine
Pool volume (gallons): 25,000
Feature conditions: Outdoor, good filtration, uncovered pool
Bather load: Moderate
Water temperature: 80°F

Ozone sizing calculations

Calculating the feature's full flowrate

Formula: volume/360 minutes (six-hour turnover) = full flow gpm
Example: 25,000/360 minutes = 69 gpm

Calculating the system flowrate

Calculating the ozone loop flowrate allows for proper sizing of booster pump(s), venturi(s) and contact vessel(s). This ozone loop flowrate will range from 15 to 30 percent of full flow gpm; 20 percent is typical. This percentage can also be used to determine the independent loop or side-stream loop flowrates. *NOTE: Though this calculation can be used for both independent and side-stream flowrates, the independent may have a greater flowrate due to the independent loop's pump flowrate ability (or pump curve).*

Formula: full flow gpm x desired ozone flowrate percentage = ozone loop flowrate
Example: 69 gpm x 20% = 14 gpm

Ozone output required, gph (grams per hour)

Determine ozone dosage rate based on system profile conditions. In this example, 0.25 ppm ozone will be used.

Formula: dosage rate (ozone ppm) x full flowrate x 0.228 = ozone gph

NOTE: 0.228 is a multiplier used to calculate pounds per day of ozone to gph. This is a fixed value.

Example: 0.25 ppm ozone x 69 gpm x 0.228 = 3.93 ozone gph

If working through these calculations is still intimidating, some equipment manufacturers have taken all of the complexity out of the process. Figure 5 can be used to determine the proper ozone generator, based on total volume of the feature (in gallons) and the amount chlorine the customer would like to reduce.

Standard system equipment

Once the correct amount of ozone has been determined, proper equipment must then be chosen for the project. Small, above-ground backyard spas may only require an ozone generator and an ozone injector, making equipment selection and installation very simple. As features increase in size, however, so does the equipment involved.

Ozone generator air preparation system

An air preparation system is important for the production and longevity of the ozone generator. The air preparation system, typically either an air dryer or oxygen concentrator, takes in ambient air and dries it to eliminate moisture prior to the air entering the ozone generator. This is vital, because as higher dew-point levels enter the generator, the combination of moisture and electrical arc from the ozone generator will cause nitric acid to form inside the ozone generator reaction cell (where the ozone is created). The presence of nitric acid can cause premature failure of the ozone reaction cell, requiring increased frequency of maintenance. The air dryer simply dries the air by removing the moisture or water content from the air, whereas the oxygen concentrator not only removes the moisture, but also removes the nitrogen from the air. It then concentrates oxygen purity to as much as 95 percent to be fed to the ozone generator, as opposed to the ambient 20-percent oxygen level delivered by the air dryer. By concentrating the oxygen, the concentrator feeds the generator with far more oxygen molecules to be split, increasing both the output (rated in grams per hour) and percent by weight (concentration of the ozone gas).

Ozone generator

The main component of the system, the ozone generator is manufactured in many different configurations and ozone outputs. There are two main types of generators: ultraviolet (UV) and corona discharge (CD).

UV systems produce ozone by means of an ultraviolet lamp rated at 185 nanometer (nm) wavelength light spectrum. As an oxygen molecule passes through the UV light, the molecule disassociates, creating two O₁ atoms, which then recombine

with another O₂ molecule to form ozone (O₃). UV generators are inexpensive and do not require an air preparation system, but also produce far less ozone output than that of a CD generator.

CD ozone generators create ozone via an electrical arc (or discharge) inside a specifically designed reaction cell. Similar to that of UV, the arc of the CD system splits the oxygen molecule to form ozone; however, the CD system splits far more oxygen molecules, increasing the grams per hour and concentration of ozone gas produced.

CD ozone generators require an air preparation feed gas system, although there are smaller units (which typically have output levels of 1.0 grams per hour or less, and no more than 0.3 percent by weight) that can be used with ambient air feed gas, not requiring an air prep system. Furthermore, these generators are often inexpensive, making the use and added expense of an air preparation system impractical. UV ozone generators and small CD ozone generators (that do not require air preparation) are good options for smaller features, such as above-ground spas and small above-ground pools, but do not provide great enough ozone output or concentration levels for larger bodies of water.

Electrical control

The ozone system must be controlled electrically, so that it can be energized and de-energized automatically. Manufacturers often provide electrical control boxes and other devices that can be used within the system to provide this function.

Backflow prevention

The electrically operated equipment must be kept from exposure to water. Backflow prevention devices help to prevent water ingress to the ozone generator and other equipment that can be damaged due to water.

Normal operation gauge assemblies

Ozone production or output is based on the concentration of oxygen feed gas from the air preparation system, as well as the flowrate at which it is provided to the ozone generator. These normal operating parameters should be set—with specific gauges—based on the specifications outlined in the manufacturers installation and operation manual.

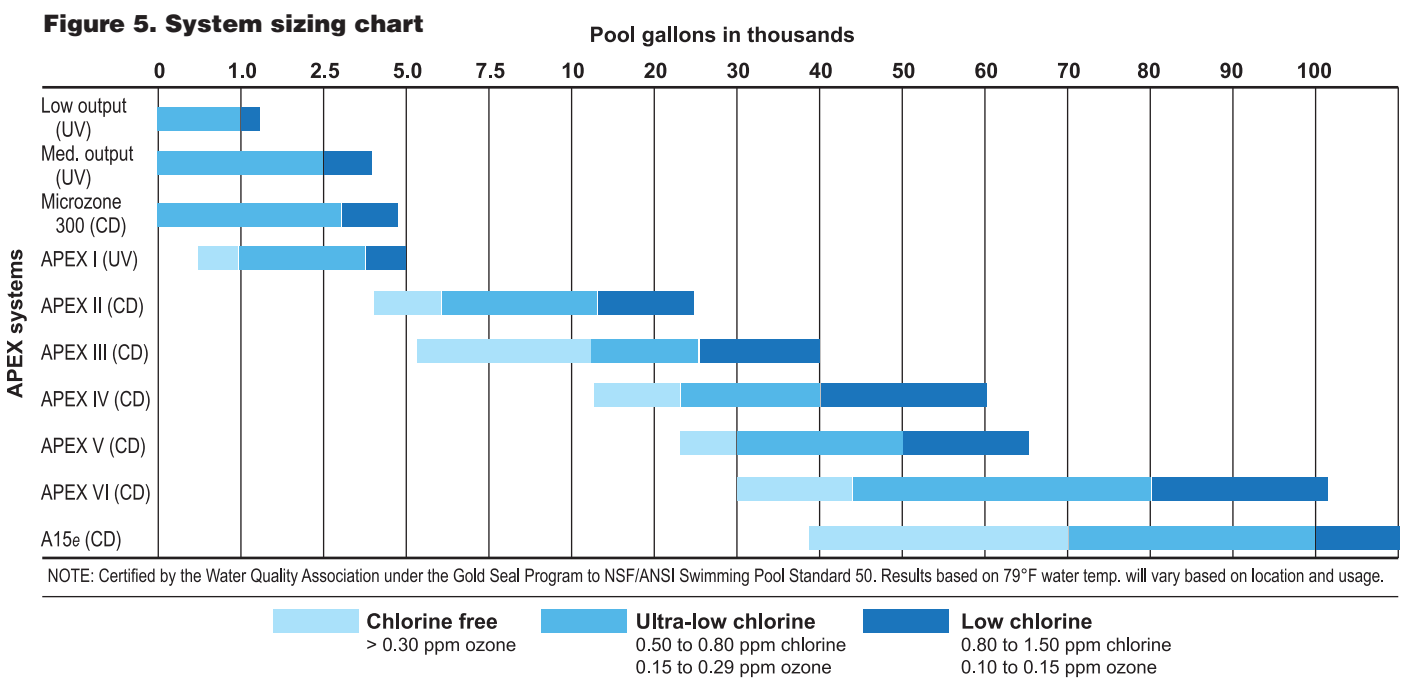
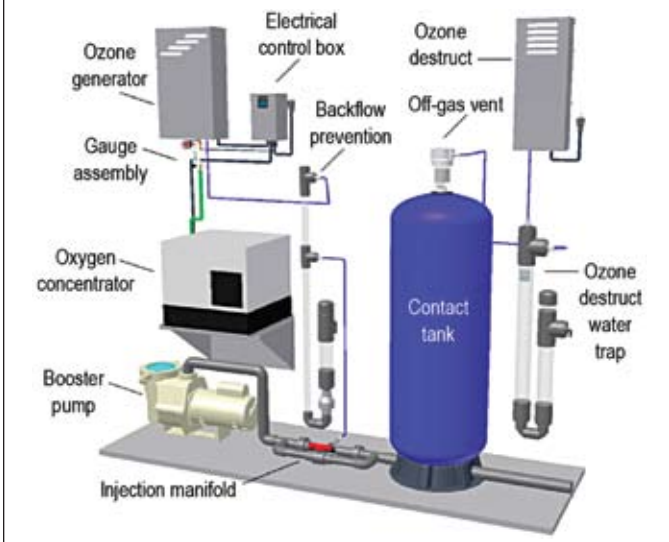

Figure 6. Ozone system components



Booster pump

The booster pump is an additional pump used to increase the pressure and/or flowrate through the ozone system injection manifold, which draws the ozone into the water line. Depending on the plumbing configuration used, this pump will either draw water directly from the pool and return it directly back to the pool (independent loop), or draw water from the pool main circulation loop downstream of the pool's filter and return the water downstream from the pool heater (side-stream loop). *NOTE: Be certain that the ozone booster pump will not draw too much water away from the pool heater. Heaters incorporate a flow or pressure switch that will not allow them to operate if too little water flow or pressure is moving through. Check the pool heater installation and operation manual prior to determining the best ozone booster pump to use.*

Ozone injection manifold

The ozone injection manifold is designed with an integral ozone Venturi injector. As water flows to the Venturi, pressure is greater and, as water flows out, pressure is lower. This creates a vacuum at the center point, at which point the ozone is drawn from the generator, thus dissolving the gas into the water.

Contact tank

All oxidizers require contact time for the oxidizer to mix with water to enable the oxidation and sanitation process. The more time the oxidizer has to contact contaminants, the further oxidation can be provided. As contact time increases, the disinfection rate of bacteria and other organics will also increase. A contact tank may or may not be used, depending upon pool or spa size, budgetary and equipment pad constraints. The contact tank will typically include an off-gas relief vent at the top, designed to keep the water under pressure within the tank, while allowing the undissolved ozone gas and oxygen to be relieved.

Ozone destruct system

If a contact tank is used, there will be an off-gasing of ozone and oxygen from the off-gas vent of the vessel. In most cases, the residual ozone and oxygen can be released directly to the outdoor atmosphere; however, if there is not a safe way to relieve the gas, then it must be destroyed properly through an off-gas destruct system.

The destruct is often a two-part system that includes a water trap and ozone destruct. The water trap will separate the water and the gas coming from the vessel. As the water drops out and is diverted to waste or drain, the ozone and oxygen mixture is sent toward the destruct unit, where it then travels through a heated catalytic chamber converting the ozone back to oxygen, where it is then vented safely to the atmosphere.

Conclusion

Ozone is becoming more and more prevalent and has now moved into the mainstream residential market as pool and spa owners are looking for a substitute that will provide a greener alternative for their water treatment needs, without the need for a lot of excess chemicals. Ozone is also an investment in bather health, safety and overall comfort, providing unparalleled water clarity that enhances swimmers' enjoyment, while simultaneously killing dangerous microbes that can grow resistant to conventional sanitizers. For some water treatment professionals, ozone is not used because it is often perceived as intimidating. While there is a learning curve involved, following these main guidelines will provide a great starting platform.

Figure 7. Residential pool ozone system



Ozone equipment manufacturers can provide further information such as schematics, sizing lessons, equipment specification and of course, one-on-one assistance. Providing ozone as an option for residential potable water treatment, as well as pool and spa treatment, can set the standard apart from those residential water treatment companies that supply only traditional products. In today's challenging economic times, the best resource is your company's own account list. Ozone applications provide water treatment professionals with the potential for increased sales.

About the author

◆ Marc De Brum is the Assistant Sales Manager/Application Engineer for ClearWater Tech, LLC of San Luis Obispo, CA. For more information related to ozone for potable water and pool and spa treatment, he can be contacted at (800) 262-0203 or by email at mdebrum@cwtozone.com.

About the product

◆ The APEX IV system uses a CD10 ozone generator from ClearWater Tech, which produces 4.0 grams per hour of ozone output with an oxygen concentrator air preparation system, which is close to the 3.93 grams per hour determined in the example and other peripheral equipment.